

Earthing Pro MV Static Earthing System

● General

Earthing Pro MV is a vehicle-mounted mobile static grounding system designed to provide tank trucks with a convenient solution for vehicle static grounding and monitoring.

"It is primarily used in locations where static dissipation equipment is unavailable or inconvenient to operate. The device is installed in a suitable position on the tank truck and powered by the vehicle's onboard battery.

During operations, the static grounding clamp is removed from the tank truck and connected to a local grounding point, enabling mobile static control and providing exceptional convenience throughout the process.

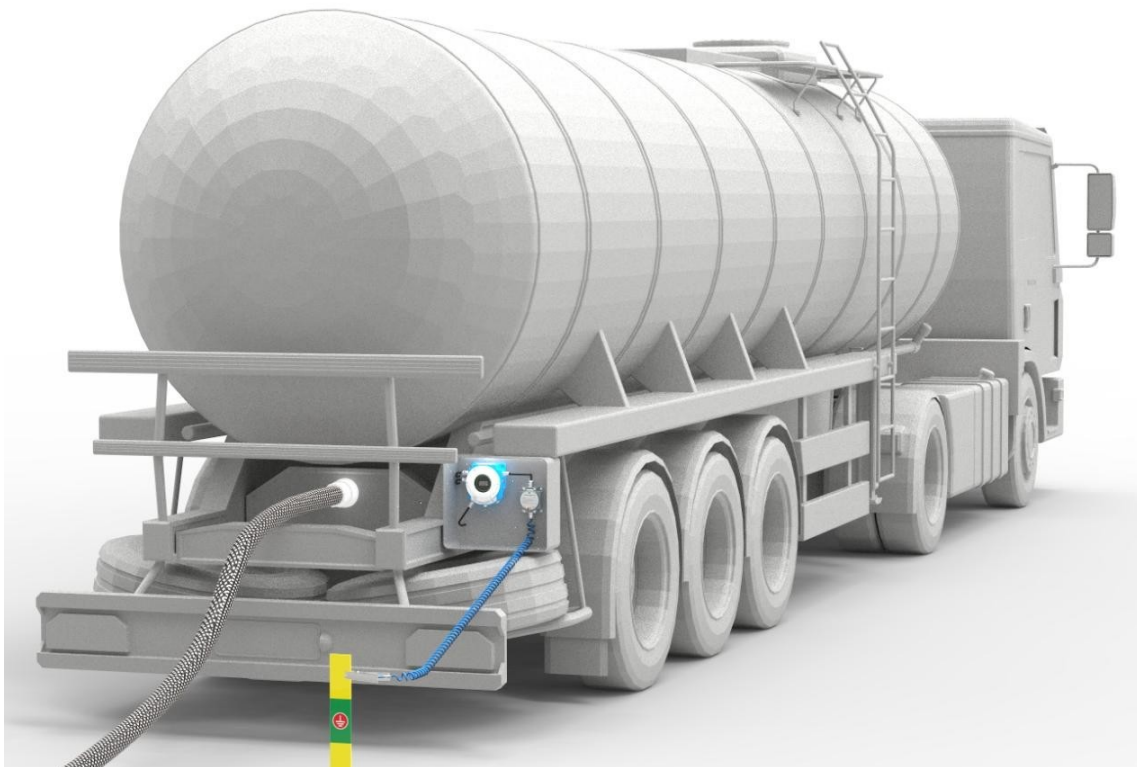

Principle of Operation

During operations, the grounding clamp must be connected to a grounding point at the worksite. To determine if a true ground connection has been established, the system sends a test signal through the grounding clamp to the tested grounding point. By measuring whether the resistance between the grounding point and the earth is within the preset range (1000Ω), the system verifies if it is connected to a true earth ground. Once this test is passed, the system confirms the grounding point as a true earth.

The system then enters real-time grounding loop resistance monitoring mode, continuously



CMC TECHNOLOGIES

PTY LIMITED ACN: 085 991 224, ABN: 47 085 991 224

Engineering &
Industrial
Instrumentation

Phone: +61 2 9669 4000
Fax: +61 2 9669 4111
Email: sales@cmctechnologies.com.au
Web Site: <http://www.cmctechnologies.net.au>

Unit 19, 77 Bourke Road,
Alexandria, NSW, 2015
AUSTRALIA

measuring the loop resistance between the vehicle body and the grounding point. When the grounding loop resistance is less than 10Ω , the system issues a permissive signal and outputs an interlock signal via a relay; conversely, the device will issue a prohibitive signal and output an interlock signal."

The Earthing Pro MV static grounding system continuously monitors the loop resistance between the grounded object and the designated grounding point. This function is field-proven and adheres to industry standards, complying with the recommendations for bonding and grounding found in IEC TS 60079-32-1, NFPA 77, and API RP 2003.

● Performance Features:

1. Highly Visible Audio-Visual Alarms

Under normal operating conditions (grounded), the ring indicator on the controller and the status lights on the junction box remain a steady green, clearly indicating that the object requiring electrostatic protection is safely grounded. If the system is in standby mode or detects a grounding loop resistance exceeding 10Ω , the lights switch to a steady red, and the buzzer on the junction box activates to sound an alarm.

2. Real-Time Ground Loop Monitoring

The system continuously monitors the resistance of the grounding loop, displaying the real-time value directly on the LED screen for full visibility.

3. Intuitive Human-Machine Interface (HMI)

The system features a user-friendly interface with graphical step-by-step instructions, guiding operators through the correct usage procedures and ensuring ease of operation, even for first-time users.

4. Grounding Detection

When the grounding clamp is connected to the grounding point at the worksite, the system outputs a test signal through the clamp to verify if it is connected to a true earth ground.

5. Interlock Signal Output

The system can be interlocked with vehicle-mounted pumps, strobe lights, or audible alarms to provide a higher level of safety protection for material loading and unloading operators.

6. Flexible Power and Signal Input

Supporting a wide input voltage range of 85–250 VAC or 24–48 VDC, the system offers flexible power options to accommodate diverse field requirements.

7. Reliable Grounding Clamps

The clamp features a serrated jaw design that penetrates paint and rust layers, ensuring reliable contact with the base metal and significantly reducing the risk of false "permit" signals.



8. Clamp Holster Function

The junction box is equipped with a dedicated holster point. After use, the grounding clamp must be returned to this holster; otherwise, the junction box will trigger an audio-visual alarm. This feature provides a secondary layer of safety protection.

- **Technical Specifications:**

Controller

Power Supply	85~250VAC/24~48VDC	
Current	<90mA	
Monitoring Resistance	≤10 Ω (Normal State)	
Operating Temperature	-40°C ~ 60°C	
Output Signal	Passive Digital Switch	
Relay Contact Rating	5A 30VDC/10A 250VDC	
Protection Rating	IP66	
Electrical Connection	7-M20x1.5	
Material	Cast Aluminum (Copper-free)	
Display	LED	
Weight	5.0kg	

Junction Box

Material	Aluminum Alloy	
Electrical Connection	2-M20*1.5	
Weight	1.8kg	



Grounding Clamp

Clamp	High-strength alloy contacts at both poles
Clamp Body	SS 304

Option 1: SC-08 Body: 304 stainless steel

Weight: 0.38 kg Paint-piercing pins: 3 × tungsten carbide

Max. Opening: 26 mm Dimensions (L × W × H): 205 × 100 × 43 mm



Option 2: SC-10 Body: 304 stainless steel

Weight: 0.32 kg Paint-piercing pins: 3 × tungsten carbide

Max. Opening: 20 mm Dimensions (L × W × H): 170 × 82 × 38 mm



Spiral Cable

Jacket	Blue Polyether TPU	
Conductor	2 x 1.5 mm ² Copper	
Length	5m,7m,10m, 13m,15m (Custom lengths available upon request)	

Certification

ATEX



II 2(1) G Ex db ia [ia Ga] IIC T6 Gb
II 2(1) D Ex ia tb [ia Ga] IIIC T80°C Db

IECEX



Ex db ia [ia Ga] IIC T6 Gb
Ex ia tb [ia Ga] IIIC T80°C Db

● Installation Kit

This component is required for equipment installation; the user needs to select one of the two types of components when placing an order.



CMC TECHNOLOGIES





PTY LIMITED ACN: 085 991 224, ABN: 47 085 991 224

Engineering & Industrial Instrumentation





Phone: +61 2 9669 4000
Fax: +61 2 9669 4111
Email: sales@cmctechnologies.com.au
Web Site: <http://www.cmctechnologies.net.au>

Unit 19, 77 Bourke Road,
Alexandria, NSW, 2015
AUSTRALIA

Kit 1

Explosion-Proof Cable Gland	Explosion-proof cable glands for non-armoured cables 7.5 mm - 12 mm Ø (x2)	
	Explosion-proof cable glands for non-armoured cables 8.7 mm - 14 mm Ø (x2).	
Grounding Wire	2x1.5 mm ² Conductor, 3 m Length	
Ex Seal Connector	4-M20*1.5;SS304	

Kit 2

Explosion-Proof Cable Gland	Explosion-proof cable glands for non-armoured cables 7.5 mm - 12 mm Ø (x2)	
	Explosion-proof cable glands for armoured cables 9.5 mm - 16 mm Ø (x2).	
Grounding Wire	2x1.5mm ² Conductor, 3m Length	
Ex Seal Connector	4-M20*1.5;SS304	



● Dimensions and Mounting

Controller Dimensions

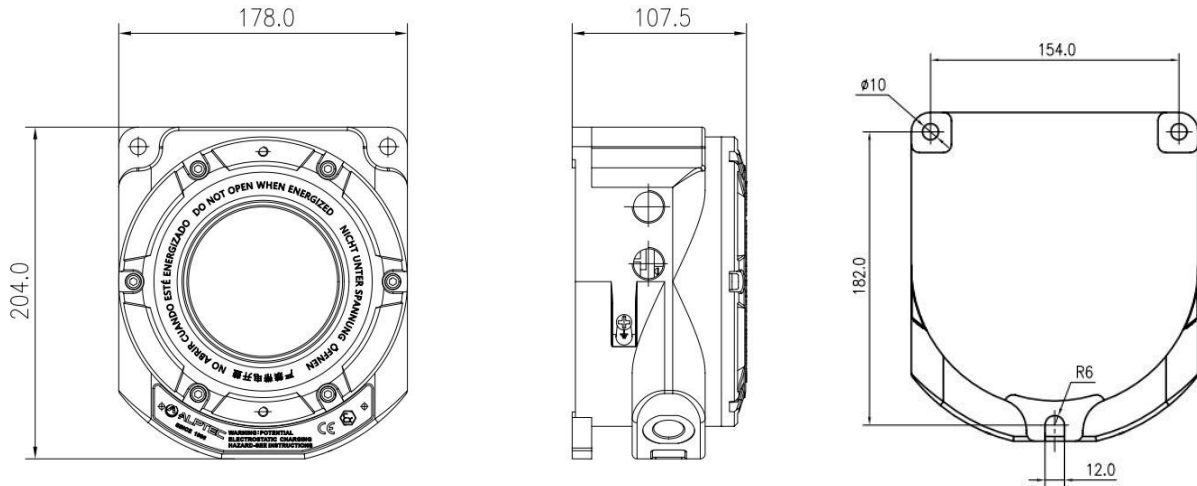

Junction Box Dimensions

