

Earthing Pro FIBC Static Earthing System

● General

The Earthing Pro FIBC system actively monitors the resistance through Type C FIBCs to verify if the bag's conductive or static-dissipative (SD) structure is below the standard requirements. By grounding the bag, the Earthing Pro FIBC mitigates the risk of incendive electrostatic discharges in hazardous locations.

It should be noted that the grounding system does not replace the test methods specified in IEC 61340-4-4. However, the grounding system can indicate that the threshold resistance of the Type C bag's static-dissipative components aligns with the specified resistance range and that a grounding loop has been established with the local verified grounding source on-site.

The responsibility for the static-dissipative performance of Type C bags lies entirely with the bag manufacturer and the on-site user.

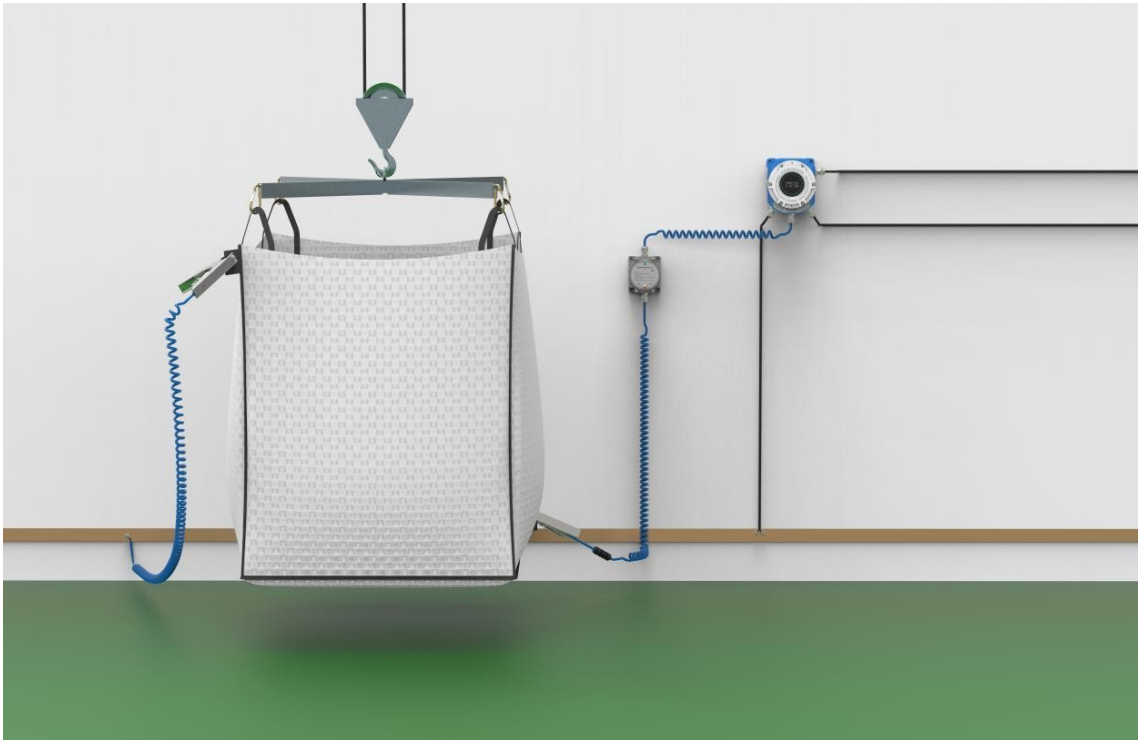

● Principle of Operation

The Earthing Pro FIBC system monitors the conductivity of Type C FIBCs in real-time, verifying if the resistance is below the preset threshold (selectable between $1 \times 10^8 \Omega$ and $1 \times 10^7 \Omega$). The Earthing Pro FIBC will only enter a permissive state and output an interlock signal when the resistance meets the preset requirements.

To ensure genuine conductivity and reliable monitoring, the system utilizes two specialized grounding clamps for Type C FIBCs. The monitoring clamp connects from the device's monitoring port to one grounding lug of the bulk bag, while the grounding clamp connects from the local



CMC TECHNOLOGIES

PTY LIMITED ACN: 085 991 224, ABN: 47 085 991 224

grounding point to the other grounding lug of the bulk bag. This configuration establishes a complete monitoring loop—'Monitor Clamp to Bag to Ground Clamp'—ensuring effective static dissipation and reliable monitoring during operations.

The Earthing Pro FIBC is a Type C bag grounding system manufactured in accordance with IEC 61340-4-4 requirements, capable of monitoring the resistance of the bag's conductive or static-dissipative components in real-time.

● **Performance Features:**

1. Highly Visible Audio-Visual Alarms

Under normal operating conditions (grounded), the ring indicator on the controller and the status lights on the junction box remain a steady green, clearly indicating that the object requiring electrostatic protection is safely grounded. If the system is in standby mode or detects a grounding loop resistance exceeding 10 Ω , the lights switch to a steady red, and the buzzer on the junction box activates to sound an alarm.

2. Real-Time Ground Loop Monitoring

The system continuously monitors the resistance of the grounding loop, displaying the real-time value directly on the LED screen for full visibility.

3. Intuitive Human-Machine Interface (HMI)

The system features a user-friendly interface with graphical step-by-step instructions, guiding operators through the correct usage procedures and ensuring ease of operation, even for first-time users.

4. Interlock Signal Output

The controller provides up to three interlock outputs, configurable as either Normally Open (NO) or Normally Closed (NC) to match the input logic of various PLCs/DCS. This flexibility simplifies system integration and retrofit projects.

5. Flexible Power and Signal Input

Supporting a wide input voltage range of 85–250 VAC or 24–48 VDC, the system offers flexible power options to accommodate diverse field requirements.

6. Clamp Holster Function

The junction box is equipped with a dedicated holster point. After use, the grounding clamp must be returned to this holster; otherwise, the junction box will trigger an audio-visual alarm. This feature provides a secondary layer of safety protection.

7. Robust Safety Design

The system adopts a design combining an "Flameproof Controller + Intrinsically Safe Junction Box + Intrinsically Safe Grounding Clamp," making it suitable for use in Zone 1 and Zone 2 hazardous areas.



● Technical Specifications:

Controller

Power Supply	85VAC~250VAC/24VDC~48VDC	
Current	<90mA	
Monitoring Resistance	≤10 Ω (Normal State)	
Operating Temperature	-40℃~60℃	
Output Signal	Passive Digital Switch	
Relay Contact Rating	5A 30VDC/10A 250VDC	
Protection Rating	IP66	
Electrical Connection	7-M20x1.5	
Material	Cast Aluminum (Copper-free)	
Display	LED	
Weight	5.0kg	

Junction Box

Material	Aluminum Alloy	
Electrical Connection	2-M20*1.5	
Weight	1.8kg	



CMC TECHNOLOGIES

PTY LIMITED ACN: 085 991 224, ABN: 47 085 991 224

Engineering &
Industrial
Instrumentation

Phone: +61 2 9669 4000
 Fax: +61 2 9669 4111
 Email: sales@cmctechnologies.com.au
 Web Site: <http://www.cmctechnologies.net.au>

Unit 19, 77 Bourke Road,
 Alexandria, NSW, 2015
 AUSTRALIA

Grounding Clamp

•	High-strength alloy contacts at both poles
Clamp Body	SS 304
SC-09	Body: 304 stainless steel
Weight: 0.25 kg	Paint-piercing pins: 3 × tungsten carbide
Max. Opening: 26 mm	Dimensions (L × W × H): 148 × 80 × 23 mm



Spiral Cable

Jacket	Blue Polyether TPU	
Conductor	1.5 mm ² Copper	
Length	5m,7m,10m, 13m,15m (Custom lengths available upon request)	

Certification:

ATEX



II 2(1) G Ex db ia [ia Ga] IIC T6 Gb
 II 2(1) D Ex ia tb [ia Ga] IIIC T80°C Db

IECEX



Ex db ia [ia Ga] IIC T6 Gb
 Ex ia tb [ia Ga] IIIC T80°C Db

● Installation Kit





This component is required for equipment installation; the user needs to select one of the two types of components when placing an order.







CMC TECHNOLOGIES

PTY LIMITED ACN: 085 991 224, ABN: 47 085 991 224

Kit 1

Explosion-Proof Cable Gland	Explosion-proof cable glands for non-armoured cables 7.5 mm - 12 mm Ø (x2)	
	Explosion-proof cable glands for non-armoured cables 8.7 mm - 14 mm Ø (x2).	
Grounding Wire	2x1.5 mm ² Conductor, 3 m Length	
Ex Seal Connector	4-M20*1.5; SS304	

Kit 2

Explosion-Proof Cable Gland	Explosion-proof cable glands for non-armoured cables 7.5 mm - 12 mm Ø (x2)	
	Explosion-proof cable glands for armoured cables 9.5 mm - 16 mm Ø (x2).	
Grounding Wire	2x1.5 mm ² Conductor, 3 m Length	
Ex Seal Connector	4-M20*1.5; SS304	



● Dimensions and Mounting

Controller Dimensions

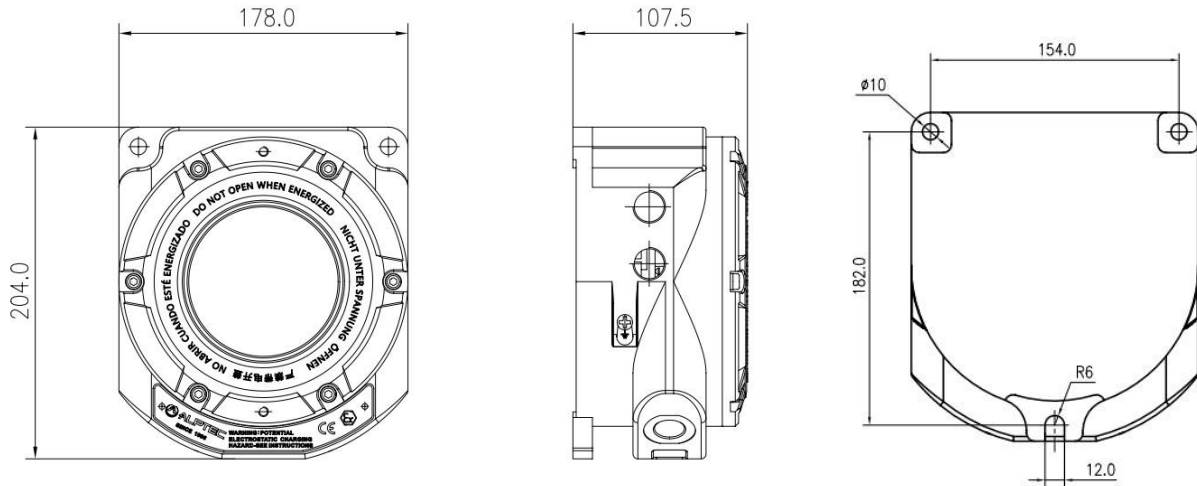

Junction Box Dimensions

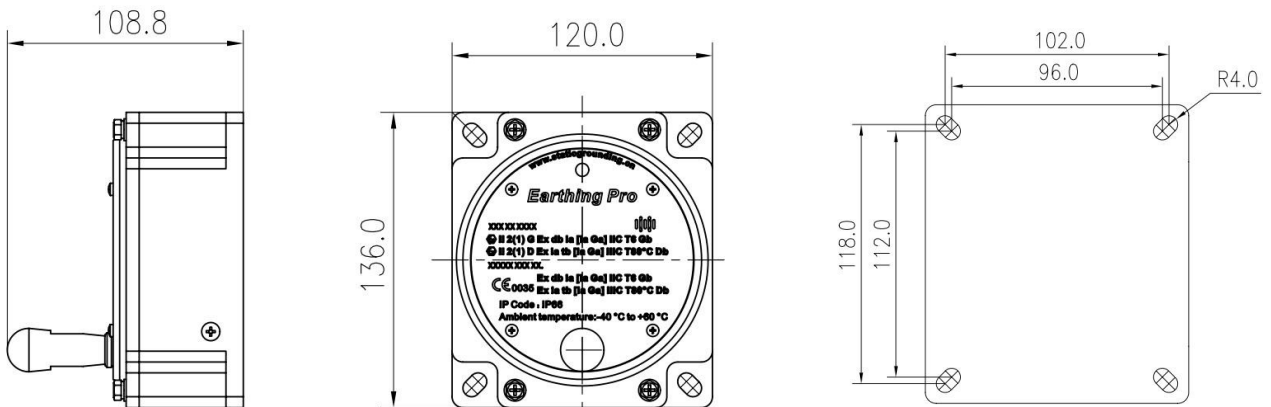

CMC TECHNOLOGIES

PTY LIMITED ACN: 085 991 224, ABN: 47 085 991 224

Engineering &
Industrial
Instrumentation

Phone: +61 2 9669 4000
 Fax: +61 2 9669 4111
 Email: sales@cmctechnologies.com.au
 Web Site: <http://www.cmctechnologies.net.au>

Unit 19, 77 Bourke Road,
 Alexandria, NSW, 2015
 AUSTRALIA