

All stainless steel (Liquid filled) capsule pressure gauge YEF(N)

Application

The product measures low pressure and negative pressure of slightly corrosive gas. It is mostly used in boiler ventilation, gas pipeline, combustion device and other similar equipment. It is widely used in petroleum, chemical, metallurgy, power, food, medical, environmental protection, machinery industries etc.

Product Executive Standard: JB/T 9274-1999

Technical Specifications

Nominal Diameter:  $\Phi 65\text{mm}$ ,  $\Phi 75\text{mm}$ ,  $\Phi 100\text{mm}$ ,  $\Phi 160\text{mm}$

Accuracy Class: Class 1.6, Class 2.5

Measuring Range:  $-60\text{kPa} \dots 4\text{kPa}$  ~  $0 \sim 250\text{Pa} \dots 60\text{kPa}$

Or other equivalent pressure vacuum ranges

Overpressure Capacity: Full Range  $\times 130\%$

Ambient Temperature:  $-40^\circ\text{C} \sim 70^\circ\text{C}$

Media Temperature:  $-40^\circ\text{C} \sim 100^\circ\text{C}$

When the ambient temperature deviates from  $20^\circ\text{C} \pm 5^\circ\text{C}$ , the indication error is lower than or equal  $0.04\% / ^\circ\text{C}$

Process Connection:  $\Phi 65\text{mm}$  M14X1.5, 1/4"NPT, G1/4"

Others: M20X1.5, 1/2"NPT, G1/2"  
(other connection as per request.)

Wetted Parts Material: 316SS

Case Material: 304SS (316SS Optional)

Movement Material: 304SS

Pressure Sensing Element: Capsule

Instrument pointer: Aluminum alloy, Black



Instrument dial: Aluminum alloy, Black letters on white background

Window:  $\Phi 65$  organic glass,

Other flat glass (Safety glass optional)

Ingress Protection: IP54, IP65, IP66

Options

Dual scale dial

Liquid filled: (glyceride, glyceride-water solution, silicon oil, fluorocarbon oil etc.)

Cooler tower (for higher medium temperature)

Panel mount (front flange, middle flange, back flange available)

Back standard blow-out hole



**Dimension**

Φ65 Bottom Connection

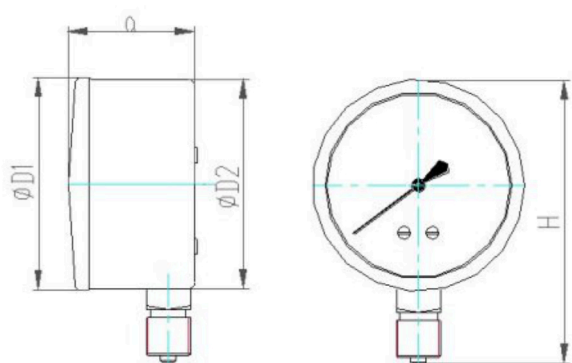

Size mm	D1	D2	a	H
Φ65	67	60	40	90

Φ65 Center back connection

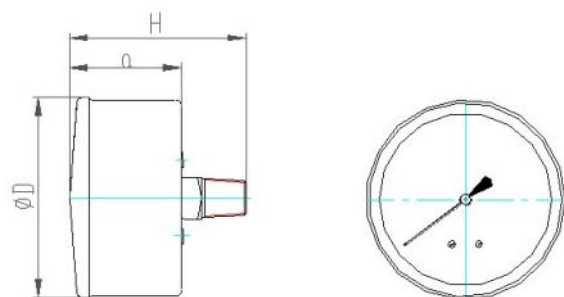

Size mm	D	a	H
Φ65	67	38	59

Φ75 Bottom Connection

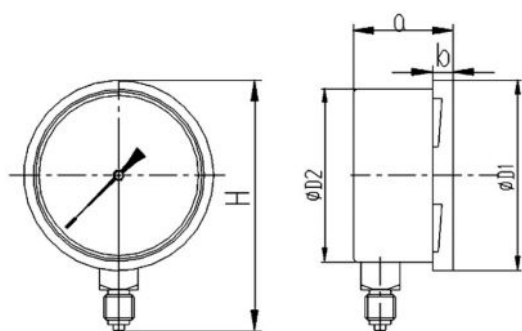

Size mm	ΦD1	ΦD2	a	b	H
Φ75	83	75.4	44	9	110

Φ75 Center Back connection

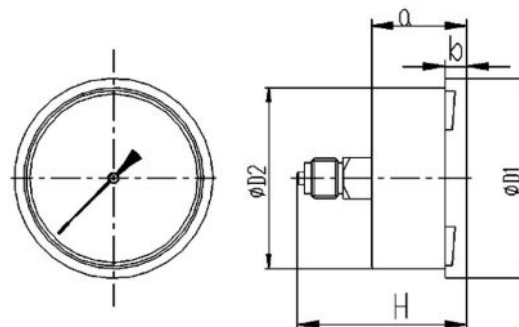

Size mm	ΦD1	ΦD2	a	b	H
Φ75	83	75.4	44	9	71

Φ100、Φ160 Bottom Connection

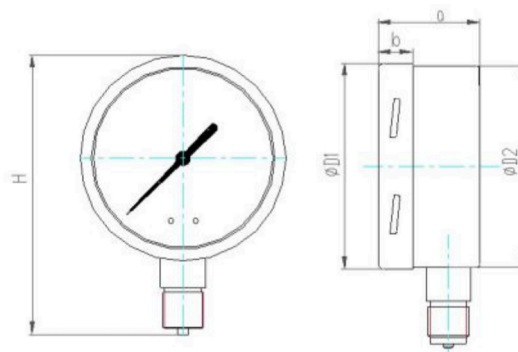

Size mm	D1	D2	a	b	H
Φ100	101	99	49.5	16	140
Φ160	161	158	49.5	17	190

Φ100、Φ160 Center Back Connection

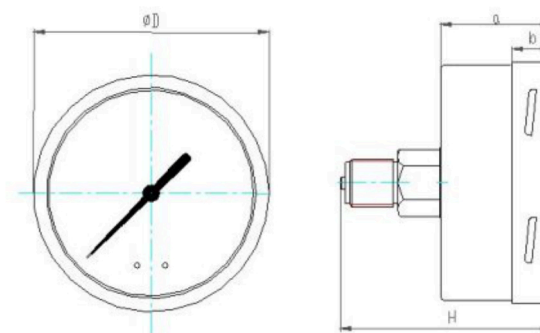

Size mm	ΦD	a	b	H
Φ100	101	48	16	89
Φ160	161	50	17	90



**CMC TECHNOLOGIES**

PTY LIMITED ACN: 085 991 224, ABN: 47 085 991 224

Phone: +61 2 9669 4000  
 Fax: +61 2 9669 4111  
 Email: [sales@cmctechnologies.com.au](mailto:sales@cmctechnologies.com.au)  
 Web Site: <http://www.cmctechnologies.net.au>

Unit 19, 77 Bourke Road,  
 Alexandria, NSW, 2015  
 AUSTRALIA

Φ 100 Bottom Connection with Front Flange

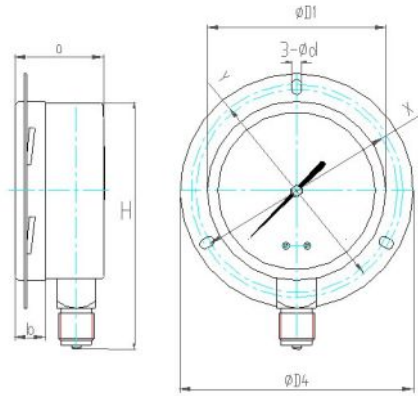

Size mm	D1	D4	d	a	b	H	X	Y
Φ 100	101	132	5.5	48	16	89	114	120

Φ 100、Φ 160 Bottom Connection with Back Flange

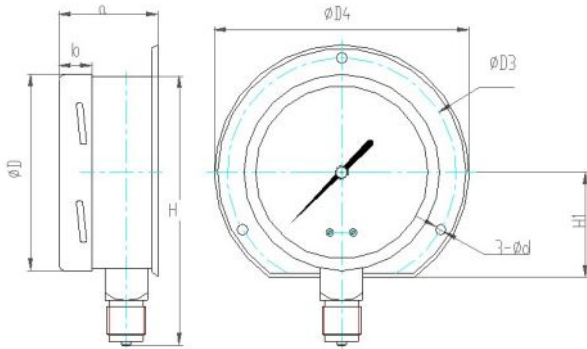

Size mm	Φ D	Φ D3	Φ D4	d	a	b	H	H1
Φ 100	101	118	131	5.5	48	16	140	54
Φ 160	161	178	196	5.8	54	17	190	86.5

Φ 100 Center Back Connection with Front Flange

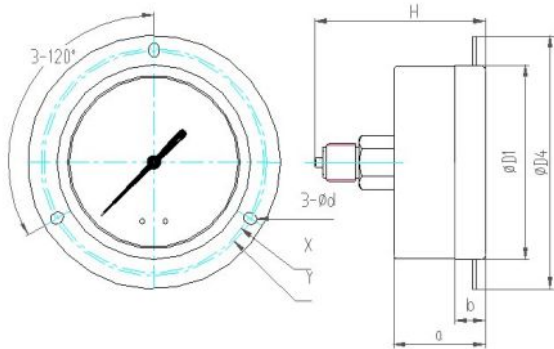

Size mm	D1	D4	d	a	b	H	X	Y
Φ 100	101	132	5.5	48	16	89	114	118

Φ 100、Φ 160 Center Back Connection with Middle Flange

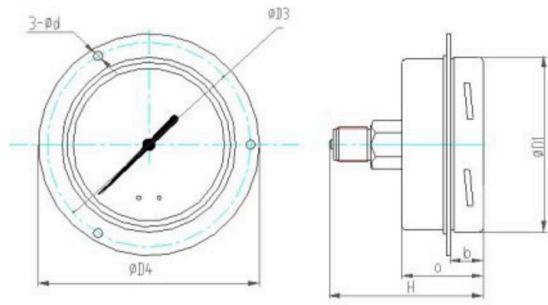

Size mm	D1	D3	D4	d	a	b	H
Φ 100	101	118	128	5.5	48	16	89
Φ 160	161	178	196	5.8	54	17	90

Φ 100、Φ 160 Center Back Connection with Back Flange

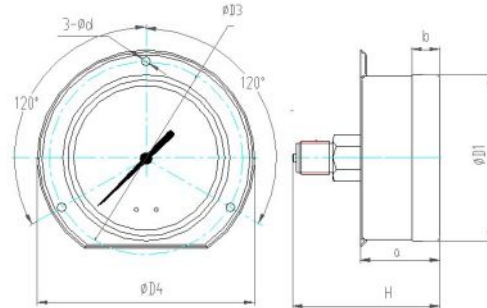

How to order

YEFN-100.AO.531.K120.M20.(Options)

YEF	All stainless steel capsule pressure gauge
N	N: anti-vibration
Liquid filled	Null : Common Type
100 Nominal Diameter	63: Φ 63mm 100: Φ 100mm 160: Φ 160mm
AO Mounting Type	AO: Bottom connection without flange AT: Bottom connection with front flange AH: Bottom Connection with Back Flange ZO: Center back connection without flange ZT: Center back connection with front flange ZZ: Center back connection with middle flange ZH: Center back connection with back flange
531 Case Type	501: Stainless steel mounting type IP54 531: Stainless steel welded type IP65、IP66
K120 Measuring Range	Refer to Attached list 1 Range Code table
M20 Connection Type	Refer to Attached list 2 Threaded Code table
Others Options	Refer to Attached list 3 Others Options table

