

TECHNICAL DATA:

- Ambient temperature:
max. 50°C (for push-button operation
max. 70°C)
- Operating voltage:
24 V AC/DC, 120-230 V AC
- Power: depending on type 5 W to 15 W LED

LIGHTING TECHNICAL DATA:

- Color temperature: see table
- Luminous flux: see table
- Reflected beam angle:
Lumistar 80-LED to
Lumistar 175-LED: 18° or 30°
Lumistar 225-LED: 11° or 26°

APPLICATION:

- For use on circular sight glass fittings.
- For combination of sight glass and light glass, suitable for circular sight glass fittings to DIN 28120 or similar, DN 50 to DN 200.
- For illumination of internals of pressure vessels, tanks, bunkers, silos, stirred vessels and other normally enclosed containers in non explosion hazardous areas.
- Suitable for use in food processings.

PROTECTION:

When correctly fitted, dust and water jet tight to IP 65 and EN 60 529/ DIN VDE 0470 part 1.

MECHANICAL INSTALLATION:

Before commencing installation please read information sheet 'Important guidelines for mounting sight glass fittings...'

The luminaire is attached to the mating flange of the circular sight glass unit by two or four bolts.

A ring gasket with bridge provides the seal between luminaire and sight glass disc.

The fixing bolts (stainless steel A2) are part of the supply.

ELECTRICAL CONNECTION:

Sizes 80 to 225 are supplied with a factory-installed 3 m connection cable. Other cable lengths are available on request.

The electrical connection is made via the connection cable, which is factory-connected in the luminaire.

The Lumiglas luminaire Lumistar-LED is designed for continuous operation. It can also be supplied with a push button.

PARTS, CONSTRUCTION AND MATERIALS:

Luminaire body: corrosion resistant die cast aluminium
Paint finish: RAL 9007

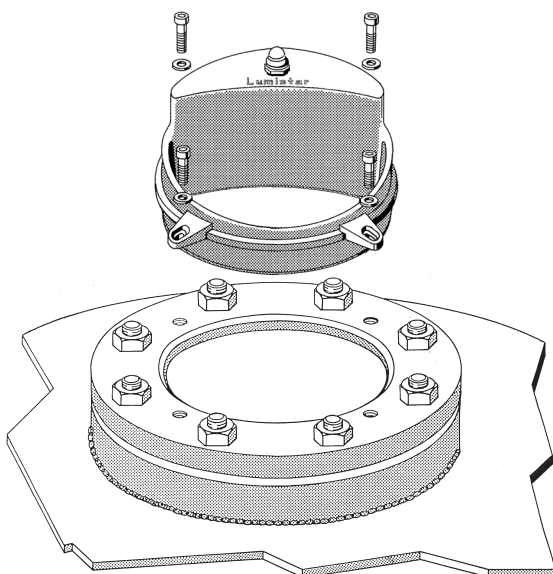

Sight- and light glasses are combined:
Lumiglas luminaire Lumistar-LED with fixing screws and sight glass fitting to DIN 28120 or similar, welded into a vessel wall

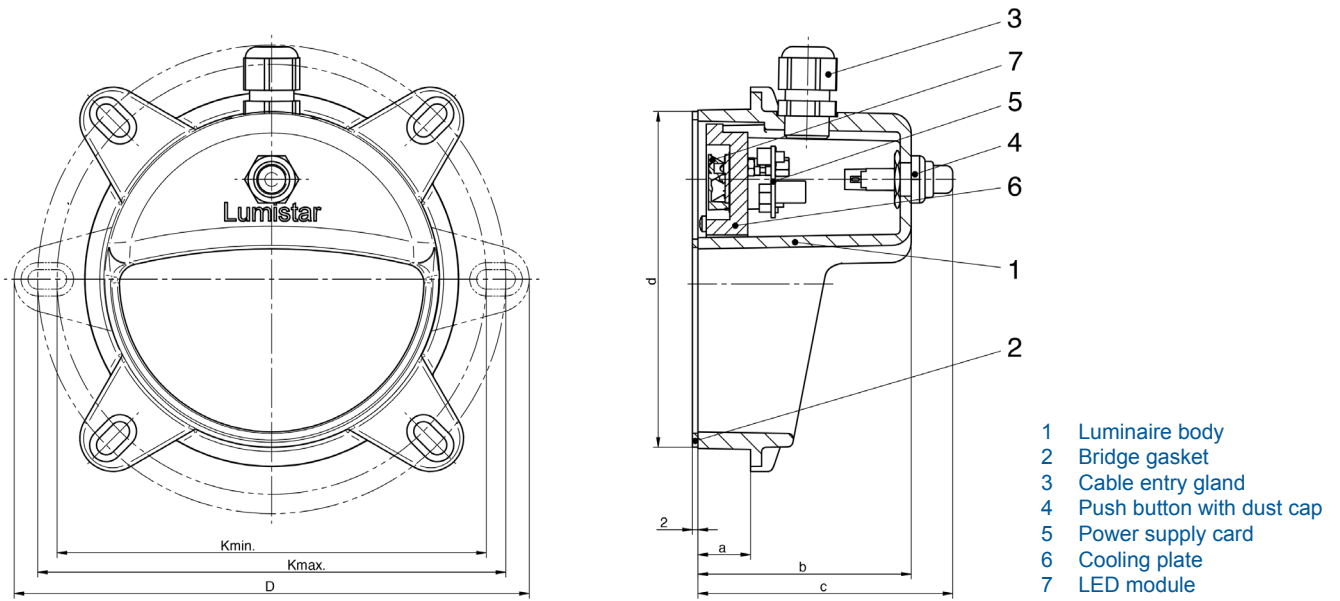

Lumistar-LED		1	2	3*	4*	5*	6*	7*
Size (= viewing diameter)		80	100	125	150	175	225	225
Matches to fitting to DIN 28120 or similar	DN	50	80	100	125	150	200	200
	Operating voltage	V	24	24	24	24	24	230
Power	W	5	6	6	6 / 10	6 / 12	15 / 15 1x7 / 2x4 LED	15 / 15 1x7 / 2x4 LED
	Bolt pitch circle Ø	K min	104	126	155	180	208	258
K max		118	140	169	194	222	282	282
D		135	157	186	211	243	303	303
d		77	97	122	147	172	222	222
a		13	17	19	22	27	32	32
b		65	75	77	80	85	95	95
c		80	90	92	95	100	110	110
Fixing oval hole		2 Pcs. 14 x 7	2 Pcs. 14 x 7	4 Pcs. 14 x 7	4 Pcs. 14 x 7	4 Pcs. 16 x 9	4 Pcs. 21 x 9	4 Pcs. 21 x 9
Bolts		M 6 x 16	M 6 x 16	M 6 x 16	M 6 x 16	M 8 x 16	M 8 x 16	M 8 x 16
Weight appx.		kg	0,300	0,450	0,550	0,650	0,800	1,400
Luminous flux		lm	450	600	600	600/950	600/1200	800/1400
Colour temp.		k	5700	5700	5700	5700	5700	5700
Part no. with push button		3544.301.00	3544.321.00	3544.341.00	3544.367.00 / 3544.361.00	3544.387.00 / 3544.381.00	3544.407.00 / 3544.401.00	3544.410.00 / 3544.404.00
Part no. without push button		3544.302.00	3544.322.00	3544.342.00	3544.368.00 / 3544.362.00	3544.388.00 / 3544.382.00	3544.408.00 / 3544.402.00	3544.411.00 / 3544.405.00

*Can be combined with Lumiglas sight glass wiper SW I.

Transformers or power supplies for 230 V AC/24 V are available on request.

Order data (for example): Lumiglas luminaire Lumistar 80-LED, part no. 3544.301.00, 24 V/5 W with push button