

Nominal Size	Clamp Size	"A"	"B"	"C"	"D"	"E"	"F"
1/2"	1 1/2"	1.984"	.370"	.813"	1.875"	1.000"	1.313"
3/4"	1 1/2"	1.984"	.620"	.813"	1.875"	1.000"	1.313"
1"	2 1/2"	3.047"	.870"	1.720"	3.000"	1.125"	1.375"
1 1/2"	2 1/2"	3.047"	1.370"	1.720"	3.000"	1.125"	1.375"
2"	3"	3.579"	1.870"	2.250"	3.500"	1.125"	1.375"
2 1/2"	4"	4.682"	2.370"	2.750"	4.500"	1.188"	1.500"
3"	4"	4.682"	2.870"	3.125"	4.500"	1.188"	1.500"
4"	6"	6.570"	3.834"	4.188"	6.500"	1.813"	2.188"
6"	8"	8.570"	5.782"	6.188"	8.438"	1.813"	2.188"
8"	10"	10.570"	7.782"	8.125"	10.438"	1.813"	2.188"

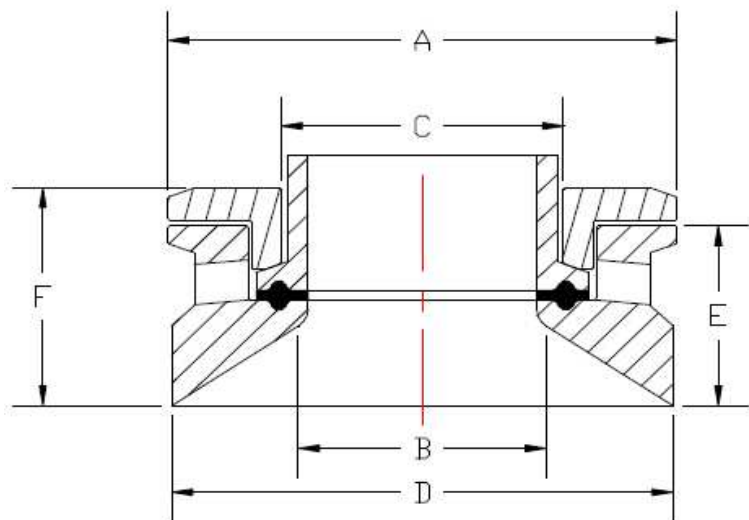

Patent Pending

**MATERIAL TYPE**

All Stainless Steel  
Nickel Alloy Material

**DELIVERY**

Stock - Ship same day if necessary  
Non-Stock - Please Inquire

**PRODUCTS APPLICATIONS**

Sight Glasses & Light Ports  
Instrumentation  
Drip & Dip Tubes  
Rupture Discs



**CMC TECHNOLOGIES**

PTY LIMITED ACN: 085 991 224, ABN: 47 085 991 224

Engineering &  
Industrial  
Instrumentation

Phone: +61 2 9669 4000  
Fax: +61 2 9669 4111  
Email: [sales@cmctechnologies.com.au](mailto:sales@cmctechnologies.com.au)  
Web Site: <http://www.cmctechnologies.net.au>

Unit 19, 77 Bourke Road,  
Alexandria, NSW, 2015  
AUSTRALIA