



## Type sheet

Bi-directional in-line deflagration flame arrester, short-time burning proof

**KITO® CFA-Def0-I-.../...-1.2**

**KITO® CFA-Def0-I-.../...-1.2-T (-TT)**

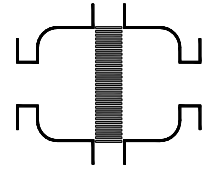

### Application

For installation into pipes to the protection of vessels and components against deflagration of flammable liquids and gases. Approved for all substances of explosion group IIA1 (old: I) with a maximum experimental safe gap (MESG)  $\geq 1.14$  mm. Bi-directionally working in pipes, whereby an operating pressure of 1.2 bar abs. and an operating temperature of 60 °C must not be exceeded. The distance between a potential ignition source and the flame arrester must not exceed 50 times the inner pipe diameter. The installation of the deflagration flame arrester into horizontal and vertical pipes is permissible. When equipped with one or two temperature sensors, the devices are protected under atmospheric conditions against a short time burning by a burning time  $t_{BT} = 1.0$  min. If only one temperature sensor, then it is to be placed on the device side where a burning could be expected.

### Dimension (mm)

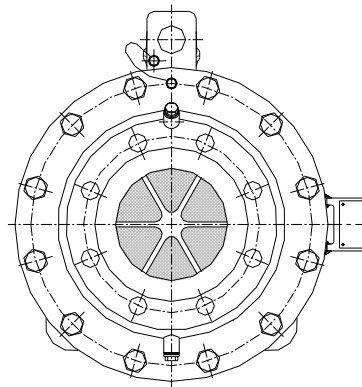
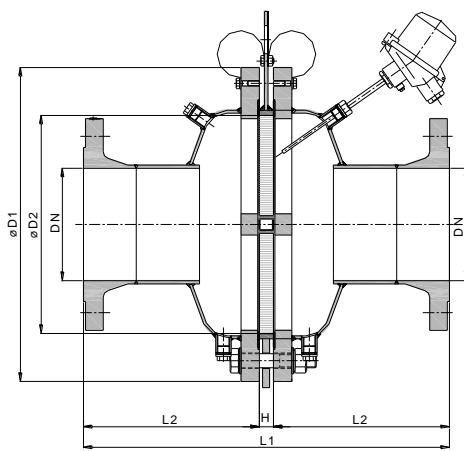

NG	DN		D1	D2	L1	H	L2	kg
	DIN	ASME						
150	50 PN 16	2"	285	159	280	20	130	30
	65 PN 16	2 1/2"						30
	80 PN 16	3"						32
200	80 PN 16	3"	340	206	330	20	155	44
	100 PN 16	4"						45
	100 PN 16	4"						66
300	125 PN 16	5"	445	308	520	20	250	73
	150 PN 16	6"						83
	150 PN 16	6"						117
400	150 PN 16	6"	565	388	620	20	300	124
	200 PN 10	8"						168
	200 PN 10	8"						176
500	250 PN 10	10"	670	485	780	20	380	244
	250 PN 10	10"						249
	300 PN 10	12"						
600	300 PN 10	12"	780	584	920	20	450	
	350 PN 10	14"						
	400 PN 10	16"						
800	350 PN 10	14"	1015	815	947	47	450	
	400 PN 10	16"						

Weight refers to the standard design

### Example for order

**KITO® CFA-Def0-I-150/65-1.2-T**

(Design NG 150 with flange connection DN 65 PN 16 and a temperature sensor)

**Type examination certificate to EN ISO 16852 and CE-marking in accordance to ATEX-Directive 2014/34/EU**

## Type sheet

Bi-directional in-line deflagration flame arrester, short-time burning proof

**KITO® CFA-Def0-I-.../...-1.2**

**KITO® CFA-Def0-I-.../...-1.2-T (-TT)**

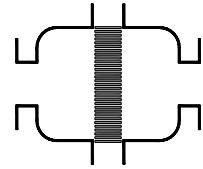

### Design

	standard	optionally
housing	steel	stainless steel mat. no. 1.4571
gasket	HD 3822	PTFE
KITO®-flame arrester element	completely interchangeable	
KITO®-casing	steel (galvanized to NG 400)	stainless steel mat. no. 1.4571 or 1.4581
KITO®-grid	stainless steel mat. no. 1.4310	stainless steel mat. no. 1.4571
bolts / nuts	galvanized steel	A2
temperature sensor		PT 100, connection 3/8", 1.4571
flange connection	EN 1092-1 type B1	ASME B16.5 Class 150 RF

### Performance curves

Flow capacity V based on air of a density  $\rho = 1.29 \text{ kg/m}^3$  at  $T = 273 \text{ K}$  and atmospheric pressure  $p = 1.013 \text{ mbar}$ . For other gases the flow can be approximately calculated by

$$\dot{V} = \dot{V}_b \cdot \sqrt{\frac{\rho_b}{1.29}} \quad \text{or} \quad \dot{V}_b = \dot{V} \cdot \sqrt{\frac{1.29}{\rho_b}}$$

