

Material	304/1.4301
Application	Light - Normal Duty
Safety Feature	Safety Gate & Eye-Bolt

PHARMACEUTICAL SAFETY CLAMPS 3 SEG SAF-TYPE

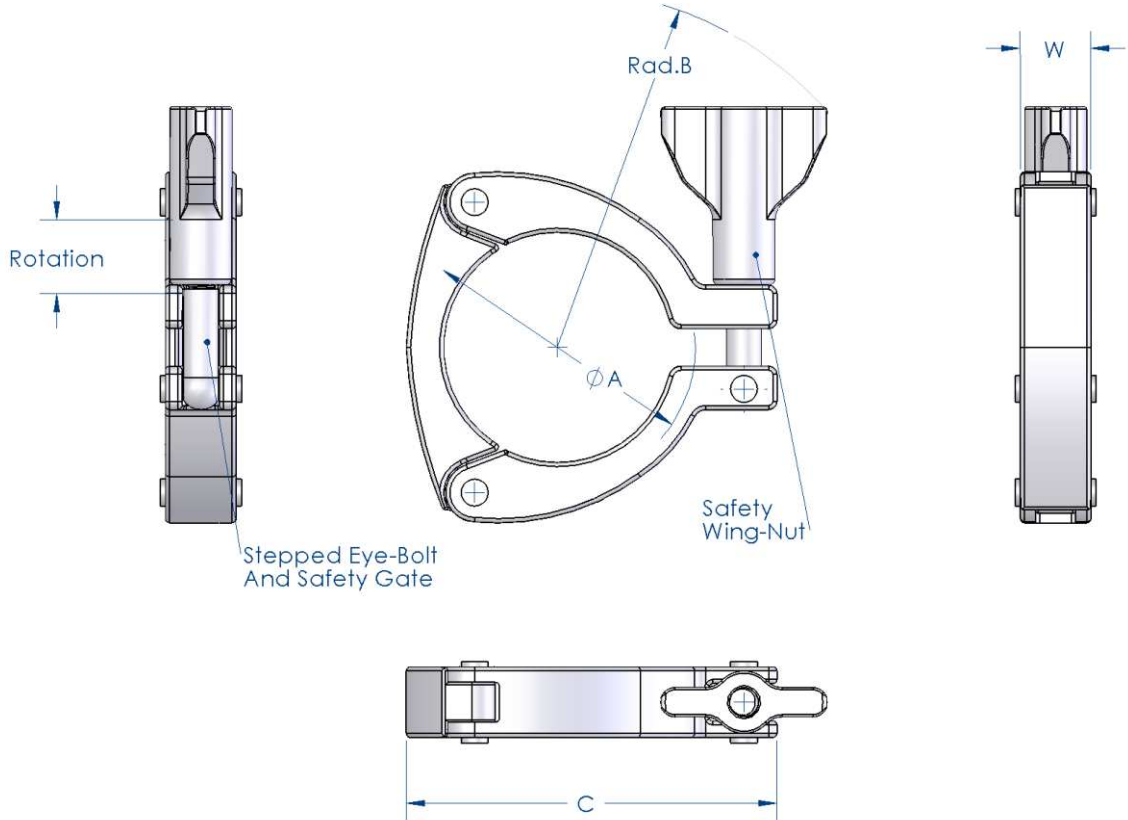

3SAF - 3 SEGMENT SAFETY CLAMP SAFETY GATE / STEPPED EYEBOLT RECESSED WING-NUT

SAFETY CLAMP - SAF3							
Nominal Clamp Size	Dimension (mm)				Wing-Nut Release Rotations	Mass (Kg)	Ordering Codes 3 SEG
	Flange ØA	Rad. B	Length C	Width W			
1"-1 1/2"	50.5	76.5	81.7	19.0	10	0.37	CL.SAF3.0100
2"	64.0	82.0	93.5	19.0	10	0.42	CL.SAF3.0200
2 1/2"	77.5	87.0	109.0	19.5	10	0.49	CL.SAF3.0250
3"	91.0	96.0	126.5	19.5	10	0.63	CL.SAF3.0300
4"	119.0	124.0	150.0	19.5	10	0.80	CL.SAF3.0400

Wing-nut rotations are measured from the clamp starting in its optimum clamping position (segments parallel when assembled), to the safety eyebolt being able to swing free.

One rotation = 360°

Advanced Couplings Ltd

Thwaites Bridge | Keighley | West Yorkshire | BD21 4LJ | UK
Tel : 0044 (0) 1535 669 216 | Fax: 0044 (0) 1535 610 243
e-mail : sales@advanced-couplings.co.uk
web : www.advanced-couplings.co.uk



CMC TECHNOLOGIES

PTY LIMITED ACN: 085 991 224, ABN: 47 085 991 224

Engineering & Industrial Instrumentation
Phone: +61 2 9669 4000
Fax: +61 2 9669 4111
Email: sales@cmctechnologies.com.au
Web Site: http://www.cmctechnologies.net.au

Unit 19, 77 Bourke Road,
Alexandria, NSW, 2015
AUSTRALIA