

# PHARMACEUTICAL SIGHT GLASSES SVFI - STERILE VISUAL FLOW INDICATOR

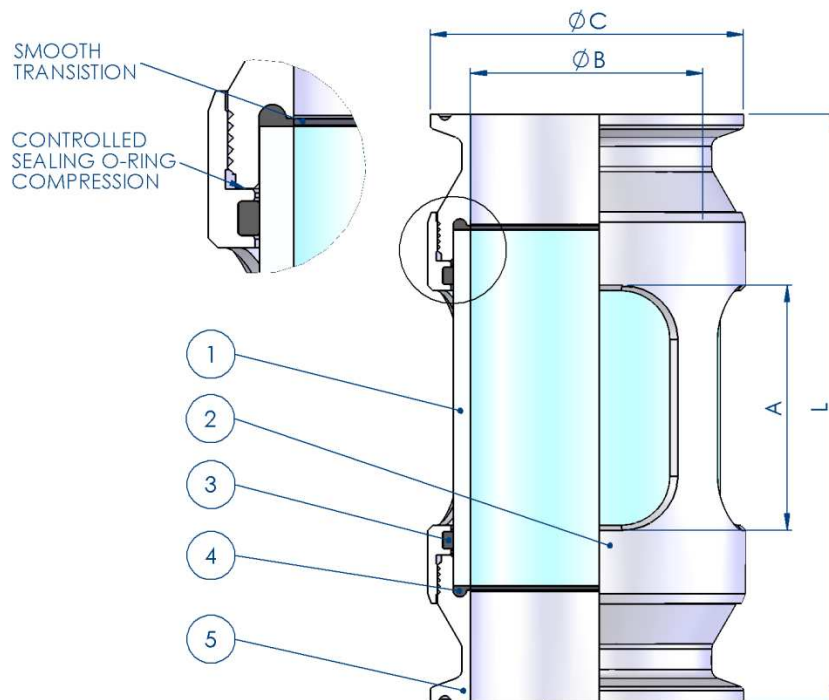

## BILL OF MATERIALS

ITEM	QTY	DESCRIPTION	MATERIAL	AVAILABLE OPTIONS
1	1	GLASS	BOROSILICATE	-
2	1	BODY	316L St St.	C22 / AL6XN
3	2	CUSHION O-RING	EPDM FDA	USP VI / FEP
4	2	SEALING O-RING	EPDM FDA	USP VI / FEP
5	2	FLANGE ENDS	316L St St.	C22 / AL6XN

## SVFI - STERILE VISUAL FLOW INDICATORS

Nominal Size Inch	Dimensions (mm)				Working Pressure (bar)	Mass (kg)	Ordering Code
	Window A x W	ID ØB	Flange ØC	Length L			
3/8"	16 X 8	7.7	25.4	65	22.0	0.09	<b>SG.SV.038</b>
1/2"	20 X 9	9.5	25.4	76	20.0	0.12	<b>SG.SV.050</b>
3/4"	27 X 11	15.8	25.4	87	17.5	0.15	<b>SG.SV.075</b>
1"	30 X 16	22.1	50.5	91	8.5	0.37	<b>SG.SV.100</b>
1 1/2"	40 X 24	34.8	50.5	105	8.0	0.40	<b>SG.SV.150</b>
2"	48 X 34	47.5	64.0	120	7.0	0.63	<b>SG.SV.200</b>
2 1/2"	55 X 40	60.3	77.5	151	6.5	1.15	<b>SG.SV.250</b>
3"	90 X 50	72.9	91.0	175	6.5	1.46	<b>SG.SV.300</b>
4"	110 X 60	97.4	119.0	200	4.0	2.78	<b>SG.SV.400</b>
6"	150 X 80	150.0	167.0	250	3.0	6.00	<b>SG.SV.600</b>

## SVFI - FLANGE INT. FINISH

Surface Finish Ra	Ordering Code
0.50	<b>.SF1</b>
0.63	<b>.SF2</b>
0.75	<b>.SF3</b>
0.38 E/Pol	<b>.SF4</b>
0.50 E/Pol	<b>.SF5</b>
0.63 E/Pol	<b>.SF6</b>

## Ordering Code Example

1" SVFI - 0.5Ra = **SG.SV.100.SF1**

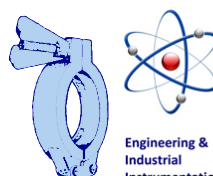

Engineering &  
Industrial  
Instrumentation

# CMC TECHNOLOGIES

PTY LIMITED ACN: 085 991 224, ABN: 47 085 991 224

Phone: +61 2 9669 4000  
Fax: +61 2 9669 4111  
Email: [sales@cmctechnologies.com.au](mailto:sales@cmctechnologies.com.au)  
Web Site: <http://www.cmctechnologies.net.au>

Unit 19, 77 Bourke Road,  
Alexandria, NSW, 2015  
AUSTRALIA