

PHARMACEUTICAL SIGHT GLASSES FVFI - FULL VIEW FLOW INDICATOR

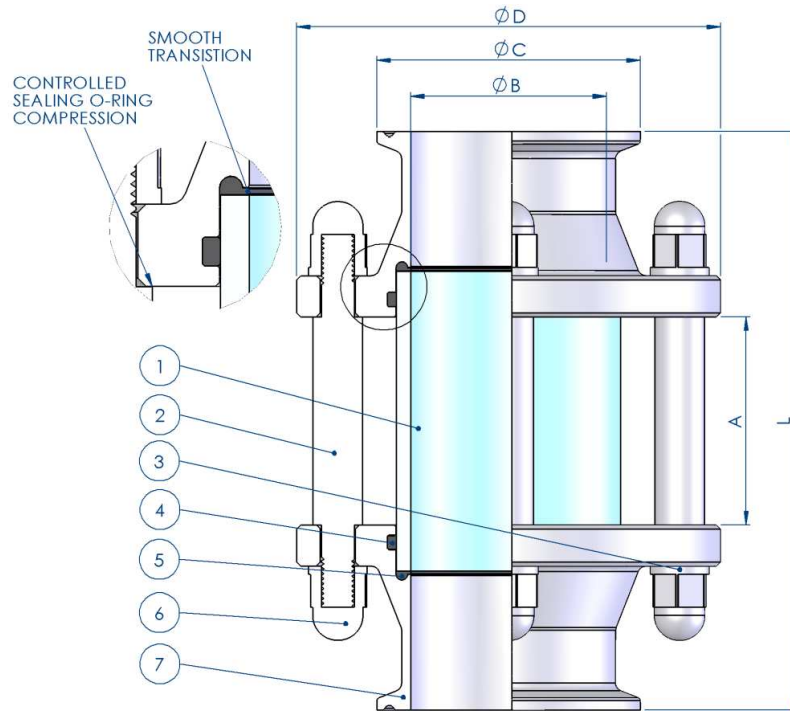

BILL OF MATERIALS

ITEM	QTY	DESCRIPTION	MATERIAL	AVAILABLE OPTIONS
1	1	GLASS	BOROSILICATE	-
* 2	4	TIE RODS	316L St St.	-
* 3	8	SPRING WASHERS	A2 304 St.St.	-
4	2	CUSHION O-RING	EPDM FDA	USP VI / FEP
5	2	SEALING O-RING	EPDM FDA	USP VI / FEP
* 6	8	DOMED NUT	316L St St.	-
7	2	FLANGE ENDS	316L St St.	C22 / AL6XN

* = Varies For Size >4"

FVFI - FULL VIEW FLOW INDICATORS

Nominal Size Inch	Dimensions (mm)					Working Pressure (bar)	Mass (kg)	Ordering Code
	View A	ID ØB	Flange ØC	OD ØD	Length L			
1/2"	27.5	9.5	25.4	50	90	20.0	0.40	SG.FV.050
3/4"	27.5	15.8	25.4	50	90	17.5	0.39	SG.FV.075
1"	33.0	22.1	50.5	70	105	8.5	0.96	SG.FV.100
1 1/2"	39.0	34.8	50.5	80	105	8.0	0.95	SG.FV.150
2"	60.0	47.5	64.0	100	140	7.0	1.56	SG.FV.200
2 1/2"	86.0	60.3	77.5	115	151	6.5	2.20	SG.FV.250
3"	90.0	72.9	91.0	127	181	6.5	2.87	SG.FV.300
4"	100.0	97.4	119.0	156	206	4.0	4.58	SG.FV.400
6"	150.0	150.0	167.0	214	254	3.0	8.41	SG.FV.600

FVFI - FLANGE INT. FINISH

Surface Finish Ra	Ordering Code
0.50	.SF1
0.63	.SF2
0.75	.SF3
0.38 E/Pd	.SF4
0.50 E/Pd	.SF5
0.63 E/Pd	.SF6

Ordering Code Example

2" FVFI - 0.75Ra = SG.FV.200.SF3

