

CE

3755.682



Lumistar luminaire ESL 25LED

- **The Lumistar luminaire ESL 25LED fits the following nominal sizes:**

- a) Circular sight glass fittings to DIN 28120: DN 25
- b) Circular sight glass fittings to DIN 28121: DN 40
- c) Flow indicators: from DN 50
- d) Screwed sight glass fittings similar to DIN 11851:
 - with DN 65, mounting is by way of separate flange adapter collar
 - from DN 80 up, the hinged bracket is possible

- **For sterile applications, a version of this Lumistar luminaire is available with a sleeve that fits over a raised lip on the mating flange.**



CMC TECHNOLOGIES

PTY LIMITED ACN: 085 991 224, ABN: 47 085 991 224

Engineering &
Industrial
Instrumentation

Phone:
Fax:
Email:
Web Site:

+61 2 9669 4000
+61 2 9669 4111
sales@cmctechnologies.com.au
<http://www.cmctechnologies.net.au>

Unit 19, 77 Bourke Road,
Alexandria, NSW, 2015
AUSTRALIA

PAPENMEIER

Lumiglas

• **Dimensions and electrical data for Lumistar luminaire ESL 25LED:**

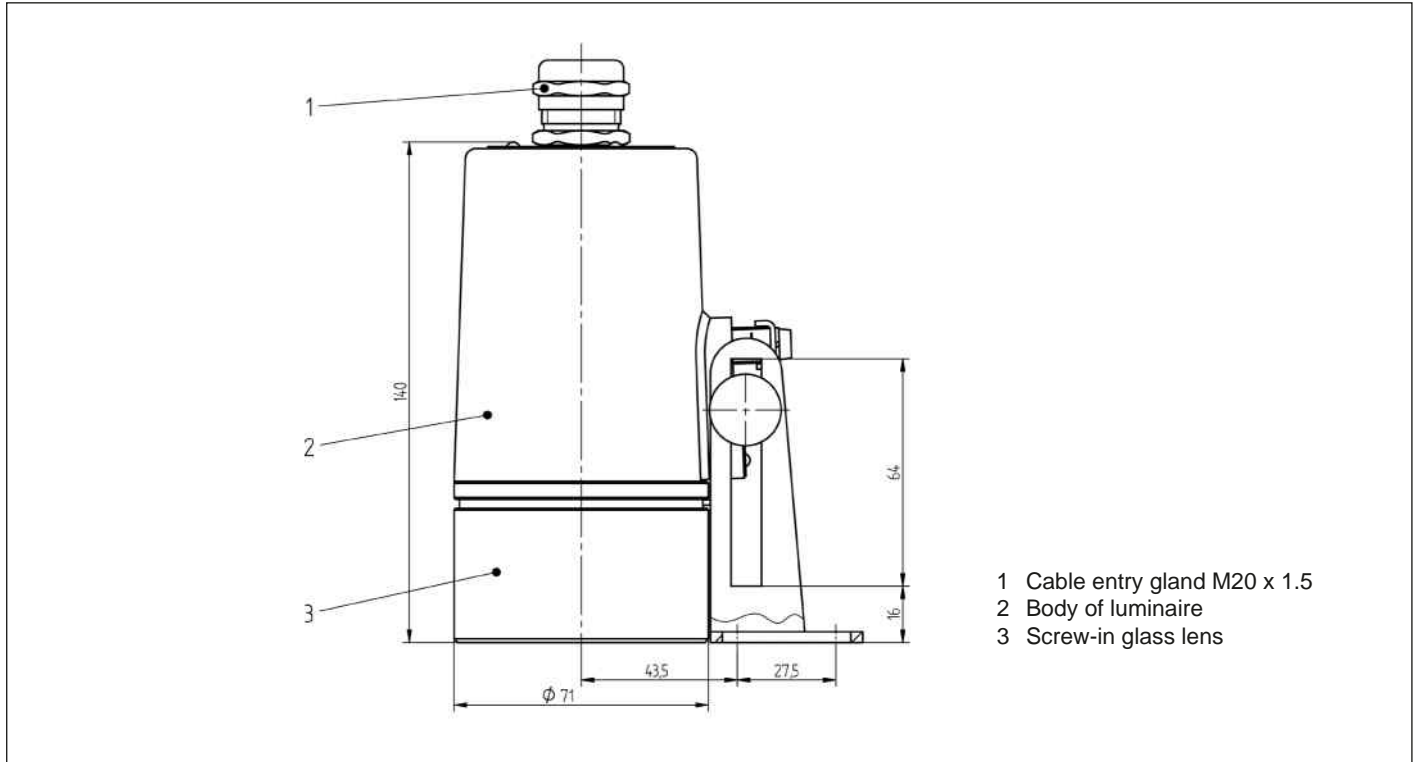

• **Components and materials:**

- Body of luminaire: Stainless steel 1.4404, polished
- Fastening components: Stainless steel 1.4301 (see 'Accessories')
- Cable entry gland: M20 x 1.5
- Weight: 1.8 kg

• **Connecting data:**

Item	ESL 25LED	Standard variants part no.	IP66 variants part no.	Ambient temperature range
1	24 V AC/DC – 7.5 W	3542.001.00	3542.003.00	$-20^{\circ}\text{C} \leq T_a \leq +50^{\circ}\text{C}$
2	110-230 V AC – 7.5 W	3542.002.00	3542.004.00	$-20^{\circ}\text{C} \leq T_a \leq +50^{\circ}\text{C}$

• **Accessories:**

Item	Component	Part no.
1	Hinged bracket mounting for luminaire	0354.019.00
2	Flanged adapter collar mounting: MV 50 – welded on; MV 65 – Ø 80 mm	1356.010.00
3	Flanged adapter collar mounting: MV 80 – Ø 94 mm	1356.029.00
4	Claw spanner for screw-in lens	6816.001.00
5	Timer module, Ex version	on request
6	Connecting cable	on request

• **Order data:**

e.g. Lumistar luminaire ESL 25LED, 24 V – 7.5 W, part no. 3542.001.00