

METAGLAS® Sight glass Discs with Tongue and Groove Joint

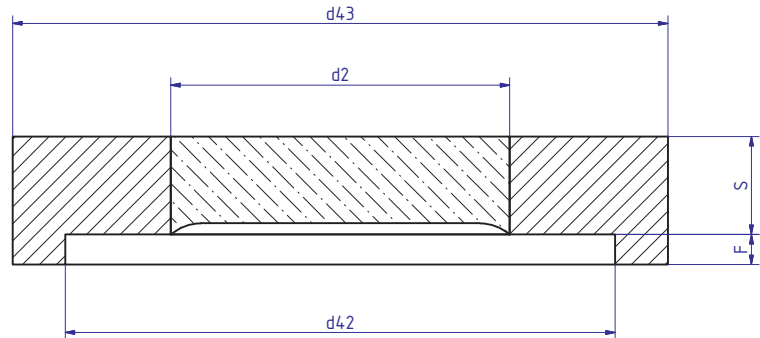
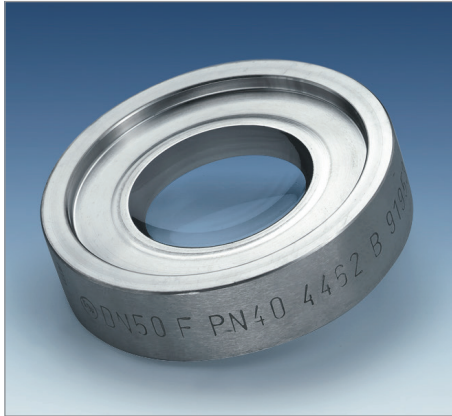

Applications

- Nozzles to DIN 28115 or 28025
- Weld neck flange DIN 2632 to 2636
- Flanges with tongue / groove based on DIN 2512 Form F Form C (E DIN EN1092-1)

Advantages

- Security against total failure
- Simple, instruction free installation
- Long operating time

Approvals and technical data

- Manufactured and tested in conformance with:
- Pressure Equipment Directive 2014/68/EU, Module H/H1 (DIN/EN/ISO 9001)
- AD2000 Standards W0/TRD 100
- TÜV Approval
- Sight glass fused to metal conforming to DIN 7079
- Borosilicate Glass to DIN 7080 / DIN 7079

Material certificates

- Certificate of Conformity EN 10204 – 3.1 or 3.2

Ring materials Temperature (TS)

Ring materials	Temperature (TS)
S355J2+N	-10°C bis +300°C
1.4462	-30°C bis +280°C
2.4602	-60°C bis +300°C
2.4605	-60°C bis +300°C
2.4610	-60°C bis +300°C

Nominal size	Maximum Pressure		40 bar		Tongue		
	16 bar		d2	S	d42	d43	F
40	d2	S	d2	S	d42	d43	F
40	35	10	35	15	61	75	4,5
50	45	13	45	17	75	87	4,5
65	60	13	60	20	95	109	4,5
80	63	15	63	20	105	120	4,5
100	70	20	70	25	129	149	5,0
125	80	20	80	30	155	175	5,0
150	100	20	100	30	183	203	5,0
200	125	30	–	–	239	259	5,0

*Approved dimensions and materials see www.metaglas.com