

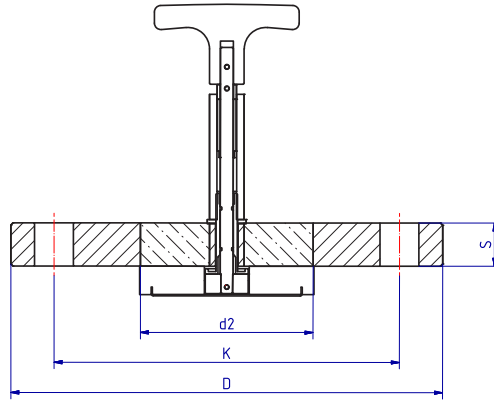

Type 13.SW

METAGLAS® Bolt on Sight glass to ANSI B16.5 – for Wiper



Applications

Flat face ANSI mating flange

Advantages

- **Reliability against total failure.** The possibility of unexpected rupture is excluded
- Long working time
- Smooth easy clean surface
- Maximum viewing
- Minimum design height
- Possible to combine with Luminaire

Technical data Manufactured and tested to:

- Directive for pressure equipment 2014/68/EU, Module H/H1 (DIN/EN/ISO 9001)
- AD Standards W0/TRD 100
- Sight glass fused to metal conforming to DIN 7079
- Materials to VdTÜV specifications and the DIN/EN designated standards
- PN10 to PN16, higher pressures possible
- Glass: Borosilicate to DIN 7080 / DIN 7079
- Fused Bush: 1.3912 (Alloy 36)

Material certificates

- Certificate of Conformity to EN 10204-3.1 or 3.2

Accessories

- Wiper
- Contact metal parts stainless steel V4A
- Wiper blade: Silicone rubber or PTFE
- O-Ring: Viton, EPDM

Important

Requires parallel flat face mounting flange and full gasket

Ring materials	Temperature (TS)
S355J2+N	-10°C bis +150°C
1.4462	-30°C bis +150°C
2.4602	-60°C bis +150°C
2.4605	-60°C bis +150°C
2.4610	-60°C bis +150°C

PN20 – 150 lb/sq.in.

Flange				Glass	Mounting holes		Gasket
DN	D	K	S	d2	n	d	
1½"	127,0	98,6	18	40	4	15,7	127,0 x 70 x 2
2"	152,4	120,7	20	50	4	19,1	152,4 x 89 x 2
2½"	177,8	139,7	20	60	4	19,1	177,8 x 100 x 2
3"	190	152,4	20	75	4	19,1	190,5 x 114 x 2
4"	228,6	190,5	20	100	8	19,1	228,6 x 152 x 2
6"	279,4	241,3	25	140	8	22,4	279,4 x 203 x 2
8"	342,9	298,5	25	160	8	22,4	342,9 x 254 x 2