

**METAGLAS® Bol-on Sight glass to ANSI B16.5**  
(Glass - concave both faces)

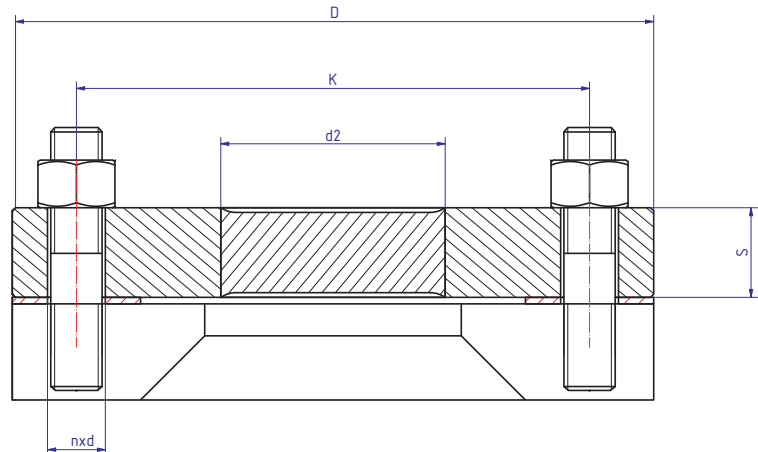
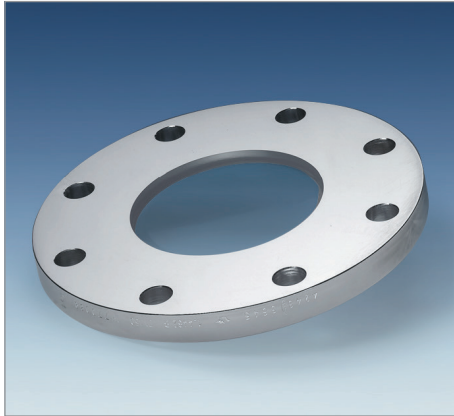

**Applications**

- Flat face ANSI mating flange

**Advantages**

- Reliability against total failure. The possibility of unexpected rupture is excluded
- Long working time
- Smooth easy clean surface
- Maximum viewing
- Minimum design height

**Ring materials      Temperature (TS)**

S355J2+N	-10°C bis +300°C
1.4462	-30°C bis +280°C
2.4602	-60°C bis +300°C
2.4605	-60°C bis +300°C
2.4610	-60°C bis +300°C

**Technical data Manufactured and tested to:**

- Directive for pressure equipment 2014/68/EU, Module H (DIN/EN/ISO 9001)
- AD2000 Standards W0/TRD 100
- Sight glass fused to metal conforming to DIN 7079
- Materials to VdTÜV specifications and the DIN/EN designated standards
- Glass: Borosilicate to DIN 7080 / DIN 7079

**Material certificates**

Certificate of Conformity to EN 10204-3.1 or 3.2 for extra costs

**Operating conditions**

- Pressure: PN20 to PN50, higher pressures possible
- Temperature: see table

**Important**

**Requires parallel flat face mounting flange and full gasket**

**PN20 – 150 lb/sq.in.**

Flange				Glass	Mounting holes		Gasket
DN	D	K	S	D2	n	d	
1½"	127,0	98,6	23	40	4	15,7	127,0 x 70 x 2
2"	152,4	120,7	23	50	4	19,1	152,4 x 89 x 2
2½"	177,8	139,7	23	60	4	19,1	177,8 x 100 x 2
3"	190,5	152,4	23	75	4	19,1	190,5 x 114 x 2
4"	228,6	190,5	23	100	8	19,1	228,6 x 152 x 2
6"	279,4	241,3	28	135	8	22,4	279,4 x 203 x 2
8"	342,9	298,5	30	160	8	22,4	342,9 x 254 x 2

**PN50 – 300 lb/sq.in.**

Flange				Glass	Mounting holes		Gasket
DN	D	K	S	D2	n	d	
1½"	155,4	114,3	30	40	4	22,3	155,4 x 73 x 2
2"	165,1	127,0	32	50	8	19,0	165,1 x 89 x 2
2½"	190,5	149,3	32	60	8	22,3	190,5 x 108 x 2
3"	209,5	168,1	35	70	8	22,3	209,5 x 127 x 2
4"	254,0	200,1	38	100	8	22,3	254,0 x 146 x 2
6"	317,5	269,7	40	125	12	22,3	317,5 x 222 x 2