

METAGLAS® for NA-Connect™ Fittings and Luminaires USL33/ESL53 or BKVLR

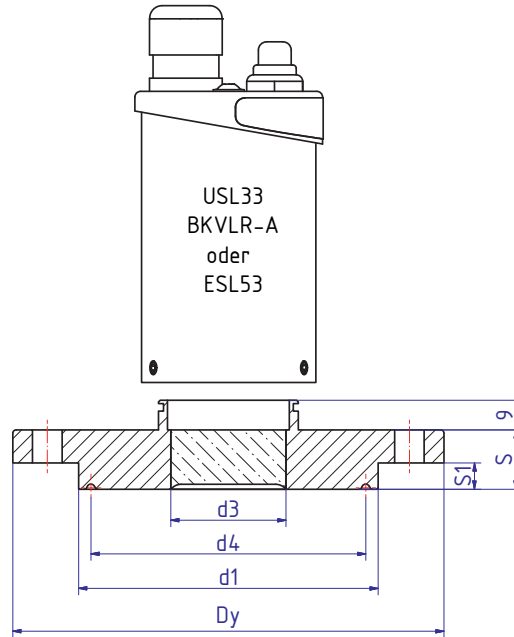

Applications

- Sanitary combination of the stainless steel luminaires and METAGLAS® to fit the flush mount NA-Connect system. Providing of intense glare free illumination through a METAGLAS® safety Glass lens.

Advantages

- Compact
- Suitable for food processing (3-A Standard)
- Dust and water jet resistant (IP65) even during external washdown
- Simple & fast installation with no risk of breakage
- Sight glass resistant to catastrophic failure
- Luminaires available with an optional push button momentary on/off switch

Operating conditions for sight glass

- Temperature: (With light) Up to 40°C
- Pressure: Up to 7 bar

Ring

materials	Temperature (TS)
1.4462	-30°C bis +280°C
2.4602	-60°C bis +300°C
2.4610	-60°C bis +300°C

Technical data Manufactured and tested to:

- Directive for pressure equipment 2014/68/EU, Module H (DIN/EN/ISO 9001)
- AD2000 Standards W0/TRD 100
- Sight glass fused to metal conforming to DIN 7079
- Materials to VdTÜV specifications and the DIN/EN designated standards
- Glass: Borosilicate to DIN 7080 / DIN 7079
- NA-Connect™
- For connector NA-Connect dimensions and technical data please request data sheet NAC00-S

For further technical information see data sheets USL33/ ESL53 Ex/Non-EX or BKVLR-A

Nominal size DIN			PN	d1	d3	d4	S1	S	Dy
DIN	ISO	ASME BPE							
25/32/40	15/20/25	1½" / 1"	7	50,5	30	43,5	7	13	85
50	32/40	2"	7	64,0	35	56,5	8	14	100
	50	2½"	7	77,5	35	70,5	8	17	112
65	65	3"	7	91,0	35	83,5	8	18	131
80	80	3½"	7	106,0	35	97,0	8	18	140
100	-	4"	7	119,0	35	110,0	7,5	19	170