

METAGLAS® for NA-Connect™ -Fitting

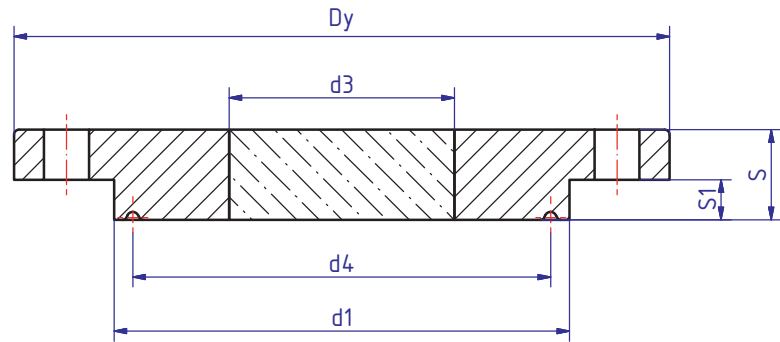

Overview

- Type 99.NA METAGLAS® is designed to fit the flush-mounted NA-Connect system to offer clear process visibility and unmatched safety with easy cleaning and sterilization.
- The NA-Connect Sight glass eliminates the dead leg created by a standard sanitary ferrule connection avoiding air pockets and trapped undissolved material.

Advantages

- Suitable for aseptic pharmaceutical and food applications (3-A Standard)
- Easy validation of connection for sterilization and cleaning
- Extremely compact construction
- Simple installation and maintenance
- Glass resistant to catastrophic failure
- Long working time

Ring

materials	Temperature (TS)
1.4462	-30°C bis +280°C
2.4602	-60°C bis +300°C
2.4610	-60°C bis +300°C

Technical data Manufactured and tested to:

- Directive for pressure equipment 2014/68/EU, Module H (DIN/EN/ISO 9001)
- AD2000 Standards W0/TRD 100
- Sight glass fused to metal conforming to DIN 7079
- Materials to VdTÜV specifications and the DIN/EN designated standards
- Glass: Borosilicate to DIN 7080 / DIN 7079

Material certificates

- Certificate of Conformity to EN 10204-3.1 or 3.2

Operating conditions

- Pressure: Up to 7 bar
- For connector NA-Connect dimensions and technical data please request data sheet NAC00-S

Nominal size			d1	d3	d4	S1	S	Dy
DIN	ISO	ASME BPE						
-	8/10	1/2" / 3/4"	25,0	13	20,2	7	11	55
10/15/20	-	-	34,0	18	27,5	7	12	70
25/32/40	15/20/25	1 1/2" / 1"	50,5	30	43,5	7	13	85
50	32/40	2"	64,0	35	56,5	8	14	100
	50	2 1/2"	77,5	40	70,5	8	17	112
65	65	3"	91,0	45	83,5	8	18	131
80	80	3 1/2"	106,0	60	97,0	8	18	140
100	-	4"	119,0	65	110,0	8	18	170
-	100	4 1/2"	130,0	70	122,0	8	20	170