

METACLAMP® Sight glass for Sanitary clamp fitting with sodalime Glass

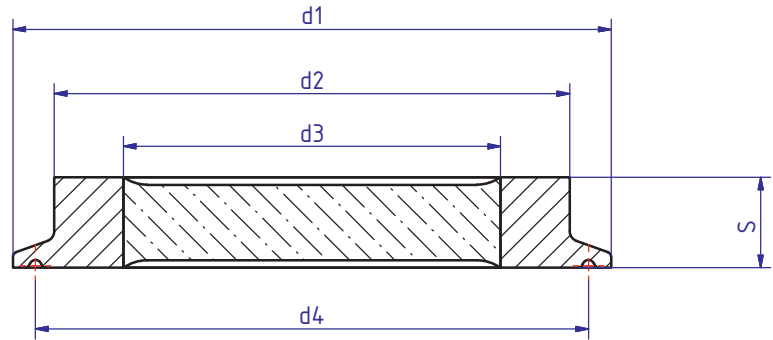
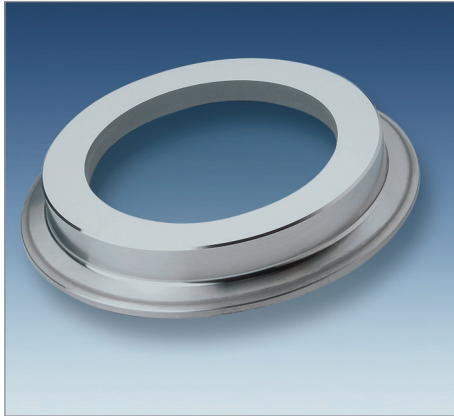

**Applications**

- For clamp fittings to DIN 32 676 / ISO 2852
- For sodalime glass approved applications

**Material certificates**

- Certificate of conformity EN 10204-3.1

**Ring**

materials	Temperature (TS)
1.4462	-10°C bis +150°C
2.4602	-60°C bis +150°C

**Technical data**

- Manufactured and tested conformance with:
- Pressure equipment directive 2014/68/EU, Module H (DIN/EN ISO 9001)
- AD 2000 standards W0/TRD 100
- Sight glass fused to metal conforming to DIN 7079
- Glass: B270 sodalime glass DIN 8902 / DIN 7079 (limited usable for pressure vessels)

**Advantages**

- Aseptic design
- Security against total fail
- Fast & simple installation & maintenance
- Long operating time
- Big glass diameter

**Operating conditions**

- Pressure: -1 to 16 bar
- Temperature: see table

Nominal size			d1	d2	d3	d4	S	max. operating pressure [bar]
DIN	ISO	ASME BPE						
25/32/40	15/20/25	1", 1½"	50,5	41	30	43,5	10	16
50	32/40	2"	64	52	37	56,5	12	16
-	50	2½"	77,5	63,5	45	70,5	14	16
65	65	3"	91	76	55	83,5	14	10
80	80	3½"	106	90	60	97,0	15	10
100	-	4"	119	102,5	75	110,0	18	10
-	-	6"	167	152	105	156,5	22	6
-	-	8"	217,5	198	135	207,4	24	6
-	-	10"	268	245	160	257,8	25	6
-	-	12"	319,3	300	200	309,1	30	6