

Metaclamp® sanitary Metaclamp & Luminaire SGL

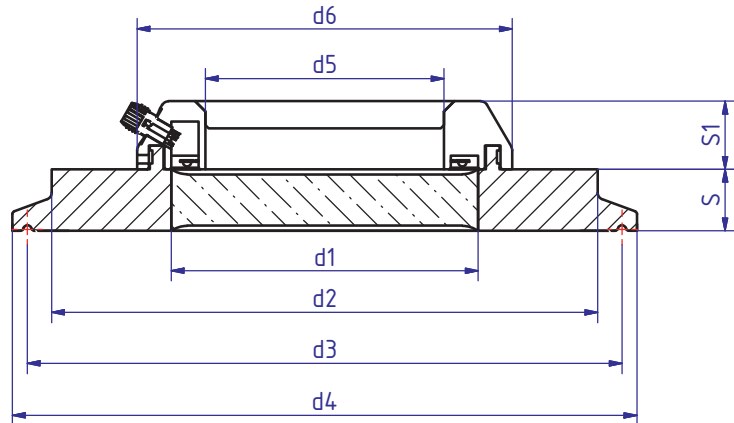

**For**

- Clamp fitting to DIN 326767 / ISO 2582 /BS4825

**Advantages**

- Space-saving application for viewing and illumination
- Sanitary design
- Safety against total failure
- Easy installation
- Long operating time

**Material certificates**

- Certificate of Conformity to EN 10204-3.1 or 3.2

**Operating conditions for sight glass**

**Ring**

materials	Temperature (TS)
1.4462	-30°C bis +280°C
2.4602	-60°C bis +300°C
2.4610	-60°C bis +300°C

**Technical datas for luminaire**

- Evenly, glare, contrasty illumination of agitators, tanks, vessels, pipes in nonhazardous areas
- Very compact, easy to clean design
- Body: 1.4404, polished
- Light color: white (WS)
- Voltage: 24VDC
- Light flux: 266 lm
- Current, continuously: 100mA
- Ambient Temperature: 0°C to 50°C
- Protection class: IP68

**Technical datas of Sight glass**

- Pressure equipment directive 2014/68/EU, AD 2000, DIN 7079
- Materials according to VdTÜV and the intended DIN/EN standards
- Glass: Borosilicate Glass according to DIN 7080 / DIN 7079

**Sight glass**

luminaire SGL	d5	d6	S1	Lumen
SGL80	40	80	40	270
SGL95	55	95	55	360
SGL110	70	110	70	400

Nominal size			d4	d2	d1	d3	S	Max operating pressure	Sight glass luminaire SGL
DIN	ISO	ASME BPE							
100	-	4"	119	101	60	110,0	12	10	SGL80
-	100	4½"	130	114	60	122,0	16	10	SGL80
-	-	5"	144,5	127	65	134,5	16	10	SGL80
125	-	5½"	155	138	70	146,0	16	6	SGL80 oder SGL95
-	-	6"	167	152	75	156,5	16	6	SGL80 oder SGL95
150	150	-	183	160	80	174,3	16	6	SGL95 oder SGL110
-	-	8"	217,5	198	100	207,4	18	6	SGL110
200	200	-	233,5	210	100	225,0	18	6	SGL110