

METAGLAS® Threaded Sight glass – NPT-Thread

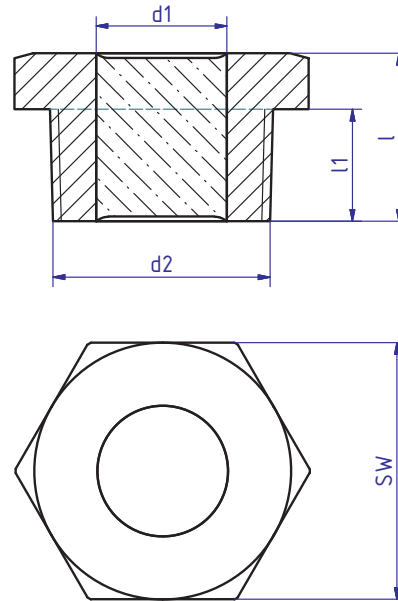
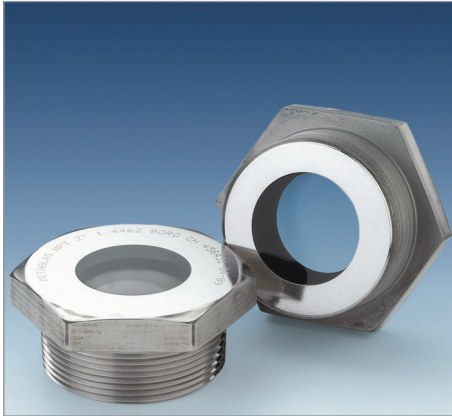

Applications

- Female connection with NPT or NPTF thread

Advantages

- Very compact
- High pressure resistance
- Simple assembly
- Long working time

Ring

materials	Temperature (TS)
S355J2+N	-10°C bis +300°C
1.4462	-30°C bis +280°C
2.4602	-60°C bis +300°C

Technical data Manufactured and tested to:

- Directive for pressure equipment 2014/68/EU, Module H (DIN/EN/ISO 9001)
- AD 2000 Standards W0/TRD 100
- Sight glass fused to metal similar to DIN 7079
- Materials to VdTÜV specifications and the DIN/EN designated standards

Materials

- Ring material: Carbon Steel S355J2+N, Stainless Steel 1.4523
- Glass: Sodalime Glass to DIN 8902

Material certificates

- Certificate of Conformity to EN 10204-3.1

Operating conditions

- Pressure: 100 bar
- Temperature: -30°C to +150°C

d2 (Thread)	SW	d1	l	l1
¼" NPT	21	8	17	11
⅜" NPT	24	10	20	13
½" NPT	31	12	25	15
¾" NPT	36	15	26	16
1" NPT	41	19	32	18
1¼" NPT	50	22	35	23
1½" NPT	55	25	32	20
2" NPT	70	35	33	22